



*Don Stephan*

A TRADITIONAL ARTISAN FURNITURE MAKER

Making custom furniture and gifts to strengthen family and celebrate friendships

## **DINING TABLE DESIGN CONSIDERATIONS**

Primary sources of information for the following are:

Dining Tables, Kim Carleton Graves, 2002

Woodworker's Guide to Furniture Design, Garth Graves, 1997

"Dining Table Design is Not As Easy as Pie," Chris Becksvoort, in Practical Design Solutions and Strategies, 2000

"Making Dining Tables That Work," Peter Tischler, Designing Furniture, 2004

### **Individual Place Setting on Tabletop**

A typical placemat might be 16" x 12" and has room for a dining plate and silverware, maybe a small glass, but nothing more.

The minimum recommended tabletop space for an individual is 24" x 16" but is really appropriate only for breakfast and VERY casual dining. A much more comfortable tabletop space for each individual is 30" x 18".

### **Chairs, Benches, Booths**

The top of a typical seat is 17-18" above the floor. Seat depth seems to be 16-18". The standard allowance for upper leg thickness when seated is 6-7", so there needs to be a minimum clear space of 23-25" between the floor and the underside of the table apron or tabletop. If cushions are used on the seats, the minimum clear space should be increased accordingly.

A typical dining chair might be 20" wide; a typical arm dining chair will be 3-6" wider. Allow 4" between chairs.

In use, the front edge of the seat is approximately even with the edge of the table.

### **Table Surface**

The center "aisle" of the dining table is used for salt & pepper shakers, condiments, casseroles, bowls, platters, candles, et cetera. The minimum center aisle width is 5" but will not comfortably accommodate much more than condiments and salad bowls; the recommended minimum center aisle width is 9".

Revised 16 January 2014 Page 1

6406 Madison Road Cincinnati OH 45227-2024 513-476-7929

[www.stephanwoodworking.com](http://www.stephanwoodworking.com)  
[www.stephanwoodworking.com/blog/wp/](http://www.stephanwoodworking.com/blog/wp/)

[don.stephan@stephanwoodworking.com](mailto:don.stephan@stephanwoodworking.com)  
[www.facebook.com/stephanwoodworking](https://www.facebook.com/stephanwoodworking)

A typical seated adult can reach and pick up items at most about 28" from the edge of the table.

### **Rectangular Tabletop**

The typical overall table width is 36" but leaves little center aisle space. The minimum recommended overall width is 40 to 42", with an optimal width of perhaps 54". Note however that a table width exceeding 40" begins to feel less intimate and more formal.

Diners seated at the ends of a dining table need an absolute minimum of 12" of table surface in front the edge, 15" is much more realistic. Diners seated along the sides of a table, as stated earlier, need an absolute minimum of 24" of width along the table, 30" is more functional. Therefore a rectangular table seating six needs an absolute minimum length of 72", with 90" much more comfortable.

When larger groups are seated only a couple times a year, it can be more practical to add a gateleg, dropleaf, or side table to one or both ends of a dining table to accommodate an extra four people.

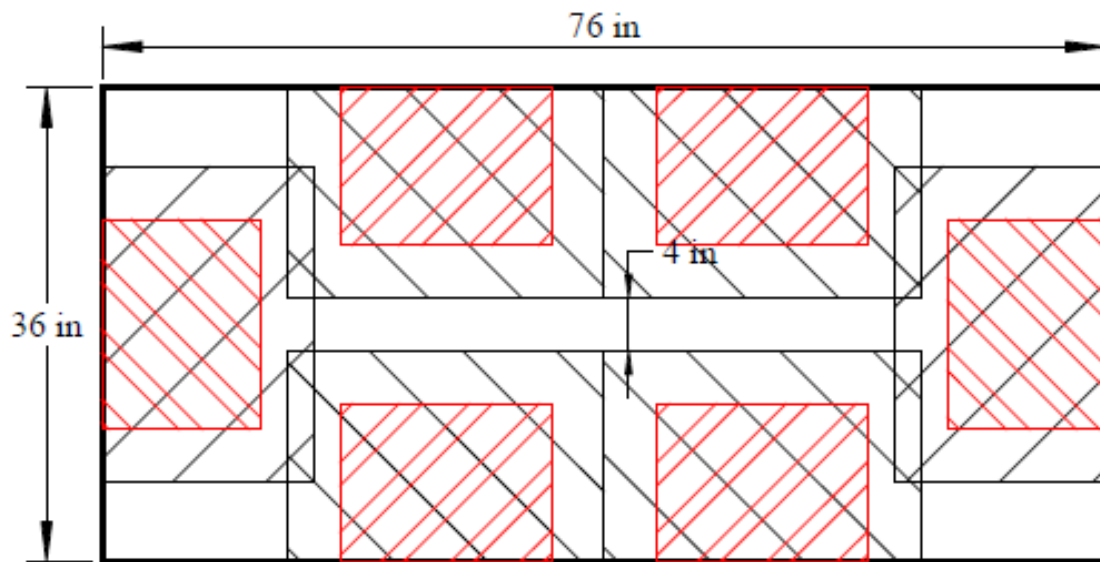

Minimum Spacing for Six, Informal Dining  
Placemats (in red) 16" x 12", "Personal Zones" 24" x 16"

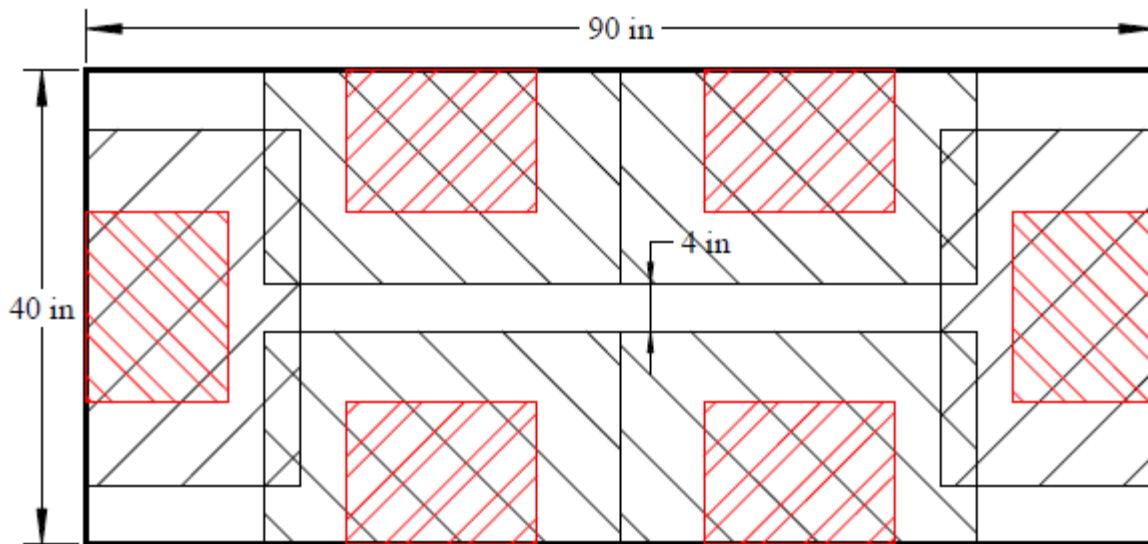

Recommended Spacing for Six, Informal Dining  
Placemats (in red) 16" x 12", "Personal Zones" 30" x 18"

### **Table Placement in Room**

There should be room around the dining table for a "seating zone" so that diners can pull out a chair, sit down, push back from the table and stand up. The minimum width of this seating zone is 36" but the recommended width is 42". The minimum width of a seating zone would be 54" for a wheelchair.

If there is normal traffic flow around the table during meals, there should be an additional "circulation zone" outside the seating zone of 24-36".

### **Table Height**

The typical dining table surface is 30" above the floor. The table top thickness usually is at least 1", but more than 1 1/2" can look overly massive.

If the tabletop is supported by individual legs, there needs to be an apron to hold the legs upright. The typical height of the apron is 4". For greater longevity, the apron should be joined to the legs with mortise and tenon joints.

### **Round Tabletop**

The absolute minimum tabletop space for a diner would be 30" of **circumference**, which theoretically would seat four at a 38" **diameter** table (having a circumference of 119"), but the useable minimum diameter is 48" (circumference 151") and the recommended diameter 60" (circumference 188"). To seat six, the minimum diameter is 60" and the recommended diameter 72". One source suggested that for a sense of intimacy and informality the maximum diameter should be 54", which would seat at most five. This last seating arrangement would have one or more people straddling a table leg on a square base. A diameter of 54" is also the maximum recommended for a single pedestal, which would accommodate five chairs much better.

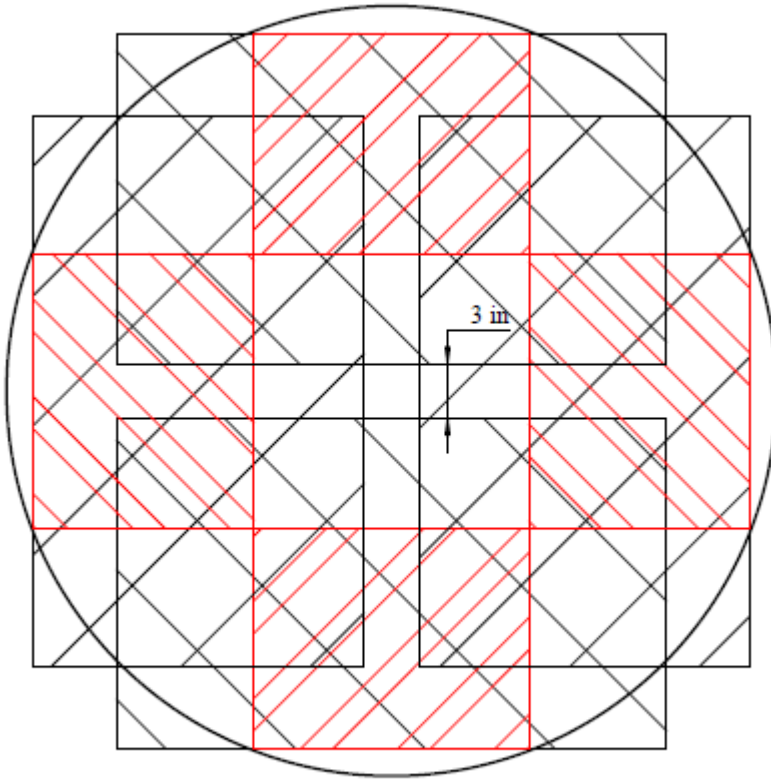

Spacing for Four, 42" Diameter  
Placemats (in red) 16" x 12", "Personal Zones" 30" x 18"

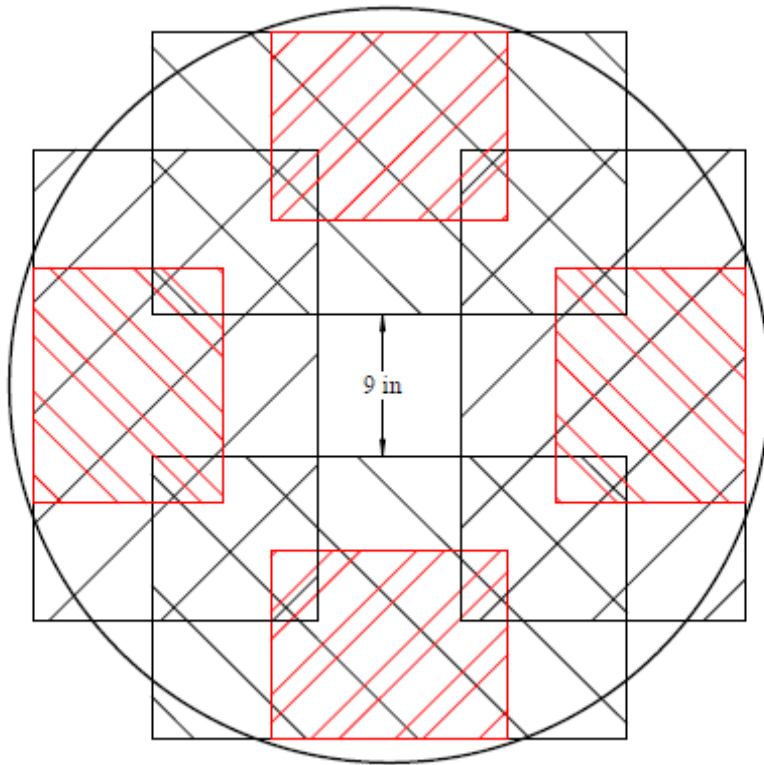

Suggested Minimum Spacing for Four, 48" Diameter Placemats (in red) 16" x 12", "Personal Zones" 30" x 18"

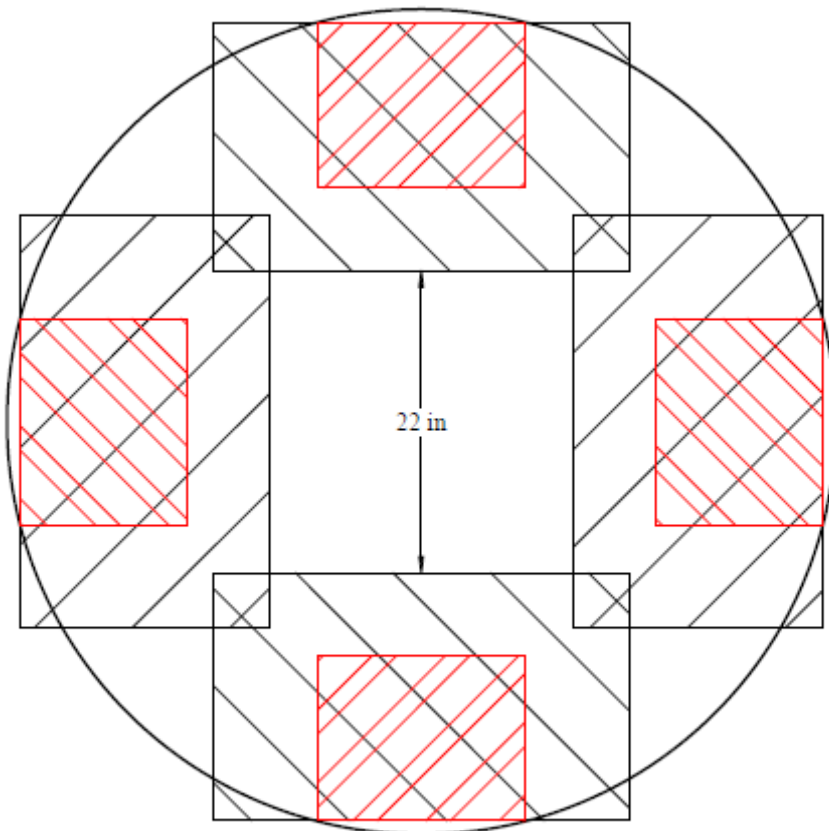

Recommended Spacing for Four, 60" Diameter  
Placemats (in red) 16" x 12", "Personal Zones" 30" x 18"

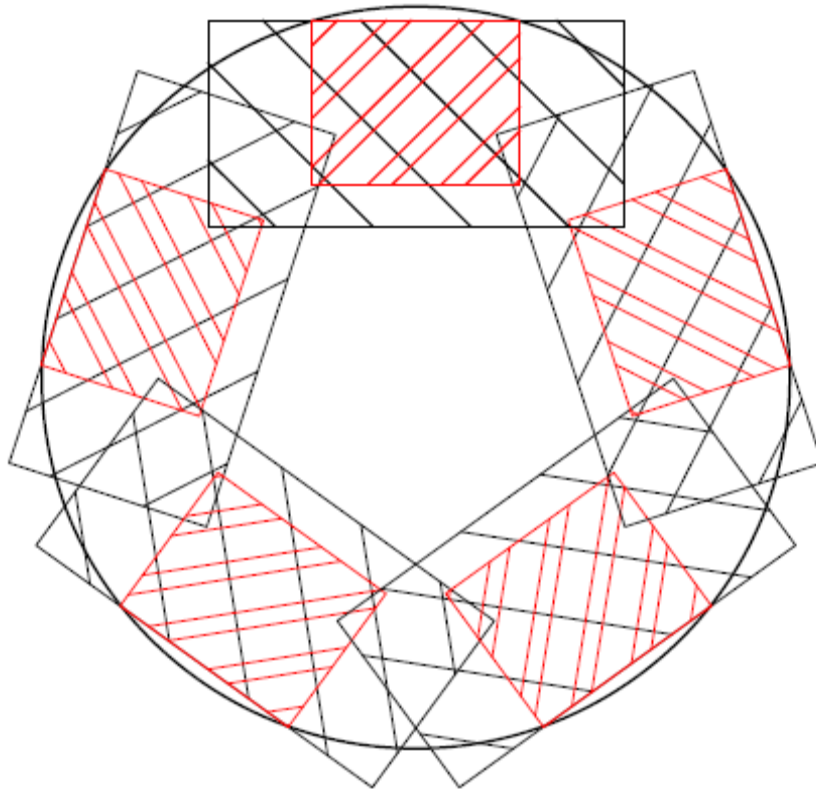

Spacing for Five, 54" Diameter  
Placemats (in red) 16" x 12", "Personal Zones" 30" x 18"  
(Max recommended diameter for single pedestal)

### **Square Tabletop**

A 32" square is about the smallest practical size to seat two people, and knees will bump. A 60" square tabletop is about the largest for functional dining, and could seat at most eight.

### **Oval Tabletop**

Many people find an oval tabletop more pleasing visually than a rectangle. But a rectangular base under an oval tabletop can pose design problems. A rectangular, 4-leg-and-apron base has a relatively narrow overhang along the sides but an extended overhang at the ends. An oval 4-leg-and-apron base is complicated and therefore more expensive to design and construct. Finally, there are compromises to the "personal zone" for each person.

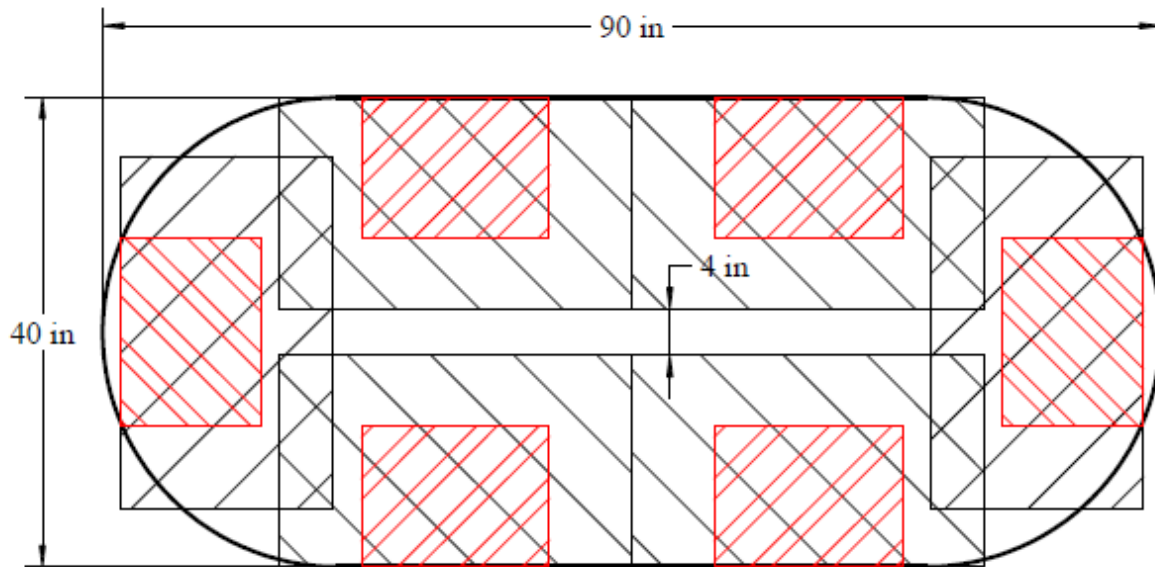

Spacing for Six, Informal Dining  
Placemats (in red) 16" x 12", "Personal Zones" 30" x 18"

### **Elliptical or Boat Tabletop**

The elliptical table may facilitate conversation between diners best, because each has a better view of the others. Many people find an elliptical tabletop more pleasing visually than a rectangle. But a rectangular base under an elliptical tabletop can pose design problems. A rectangular, 4-leg-and-apron base has a relatively narrow overhang along the sides but an extended overhang at the ends. An elliptical 4-leg-and-apron base is complicated and therefore more expensive to design and construct. Finally, there are compromises to the "personal zone" for each person.

The amount of curvature at the ends of the ellipse can be increased.



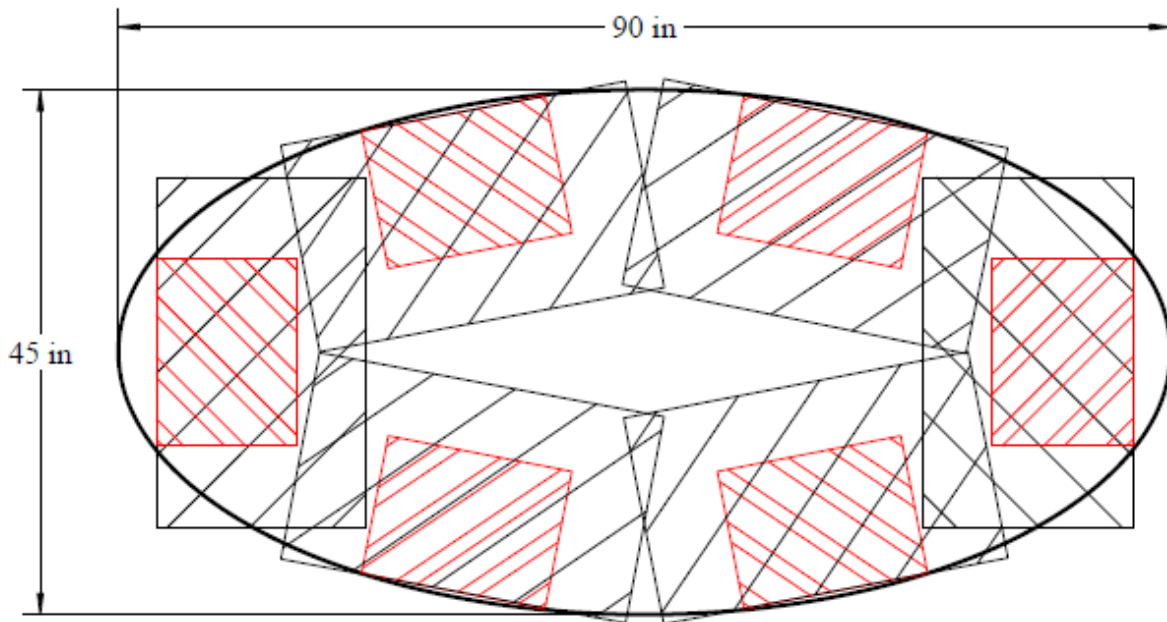

Spacing for Six, Informal Dining  
Placemats (in red) 16" x 12", "Personal Zones" 30" x 18"

### **Expanding Tabletop**

Wood or metal slides can be used to allow a table to expand at the center so that additional leaves can be inserted, increasing the table's length. To avoid potential problems with annual wood movement, these tops are more likely to be veneer on plywood or medium density fiberboard. An expanding tabletop can be based on a rectangular, round, or elliptical shape.

### **Table Base**

As a general rule, the points of contact with the floor should be within 6" of the corners of a rectangular tabletop. This is to reduce the chance of a table tipping if a child climbs on it, or an adult diner pushes down on the edge. If the table is heavier than normal, these points of contact can be no more than 12" from the corners of the tabletop.

For a round, oval or elliptical table, the "north-south" and "east-west" distances between the table legs should be within 6" of the major and minor diameters of the tabletop.

### **Table Materials**

The base is usually going to be made of solid wood or, for bent components, laminated solid wood.

The top can be made of either solid wood or a combination of solid wood edging and sheet good (plywood or medium density fiberboard – MDF).

Almost every species of wood expands and contracts across the grain enough that allowance must be made for that movement. For solid wood, a very gross approximation is 1/8" of movement per 12" of width. If a 48" wide tabletop is firmly attached to an apron down its

midpoint, there must be allowance for each side to move almost  $\frac{1}{4}$ " where its sides are attached to the apron.

As an alternative, the top can be plywood with a 3" wide band of solid wood around its sides and ends. Plywood does not expand and contract, and the edging is so narrow that expansion and contraction can be ignored. Plywood also does not cup, so the top stays flat. Birch, cherry, mahogany, maple, oak, and walnut plywoods are all commonly available in  $\frac{1}{4}$ ",  $\frac{1}{2}$ " and  $\frac{3}{4}$ " thicknesses, four feet wide and eight feet long. It probably would work to glue together  $\frac{1}{4}$ " and  $\frac{3}{4}$ " plywood to make the typical 1" tabletop thickness, but gluing together two  $\frac{1}{2}$ " layers of plywood is more likely to have balanced stresses and stay flat.

When a top will be veneered, the veneer should be applied to plywood or MDF. Some woodworkers feel plywood is acceptable for veneering, but it can have internal voids and surface unevenness that might show after the table is given a finish. MDF does not have internal voids and will always be flatter than plywood.

### **Leg And Apron Base**

The most common type of table base is four legs held together at their tops by an apron. This design is straightforward and easy to construct. It positions the legs near the corners of a rectangular top, the best location for table stability. And the legs are less likely to interfere with chair placement and seating. But this type of base works very poorly with bench seating.

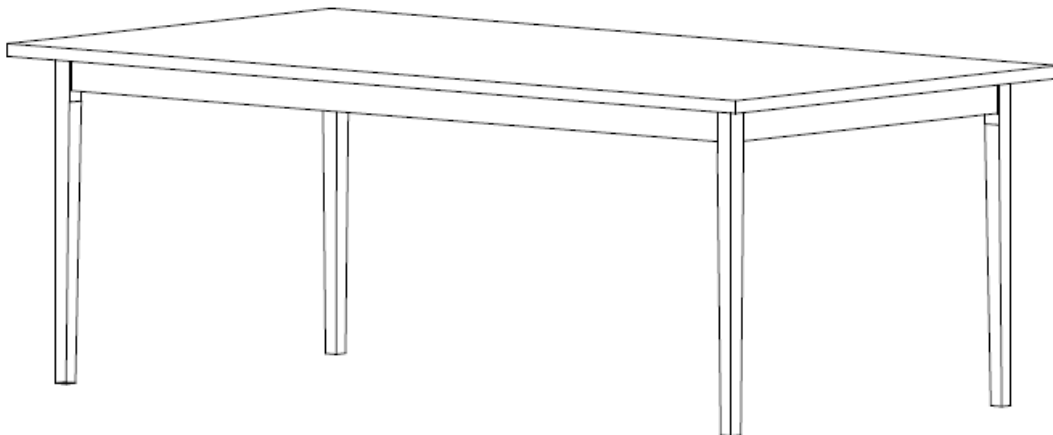

### **Pedestal Base**

As opposed to four legs, a pedestal is a single or double support. Usually but not always the pedestal is a rather thick column or urn shape. As explained earlier, the table's base needs contact with the floor within 6-12" of the extremes of the tabletop. This is accomplished with a pedestal by having a X-shaped leg structure or flat panel attached to the bottom of the pedestal. Usually there will also be a flat panel "sub-top" attached to the top of the pedestal, and this sub-top is then attached to the tabletop. To hide this sub-top, pedestal tables can have a 2-3" apron.

Supporting the table top from the middle allows more flexibility in chair placement. As a general recommendation, a single pedestal can support a round table up to 54" in diameter, and a rectangular table up to 72" long.

The following is an oval pedestal table designed to fit existing U-shaped bench seating.

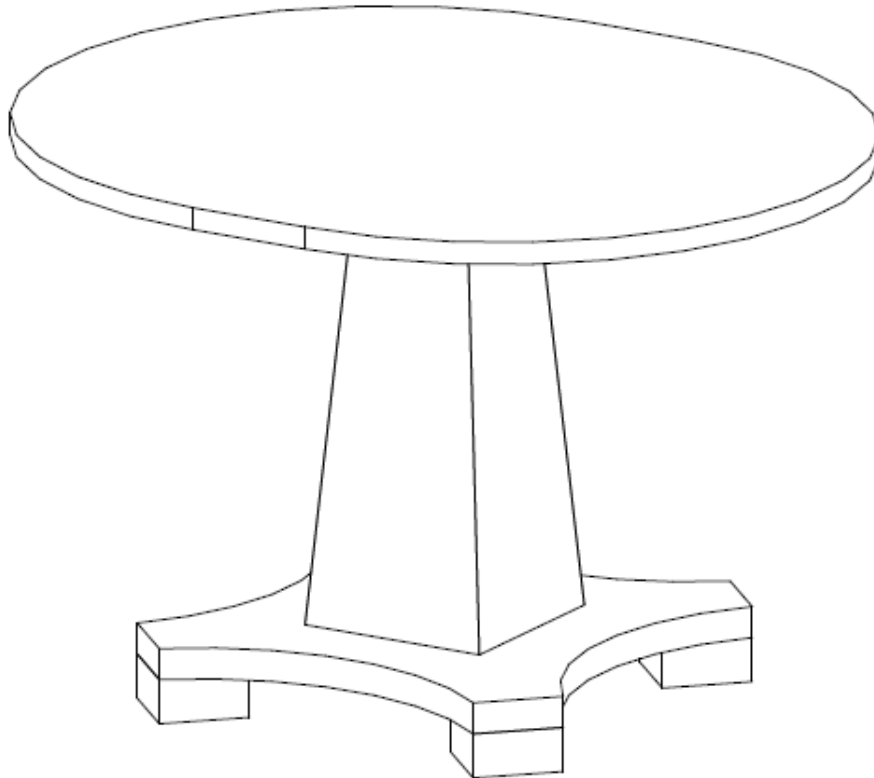

Longer tables often have a double pedestal for better structural support of the tabletop. The following is a Shaker inspired table constructed for a family with bench seating on one side and one end.

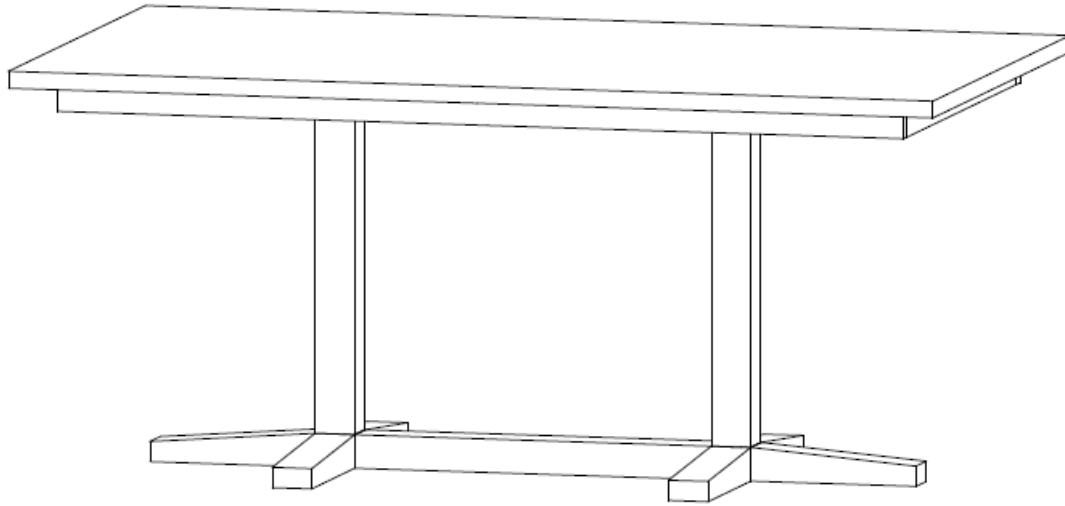

### **Trestle Base**

Often considered a Middle Ages design, a trestle base was also very popular in early America. A significant advantage was the ease with which the table could be taken down when floor space was needed for something else. In its basic form, there is a post at each end with a horizontal board or stretcher running between, perhaps 12-18" above the floor.

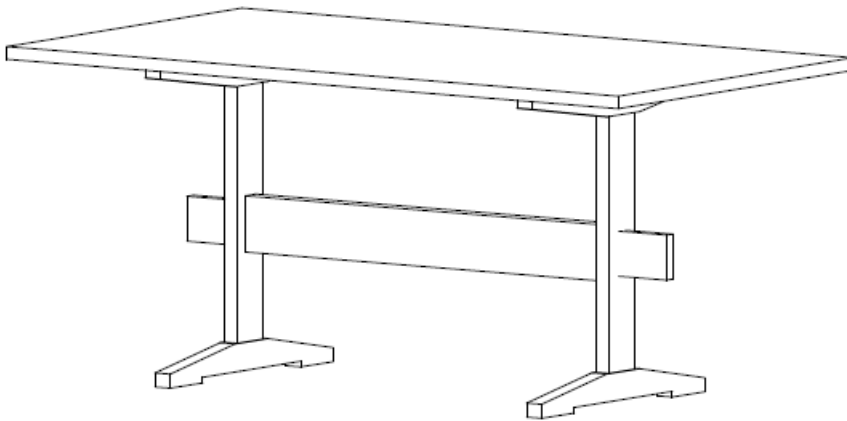

A common variation in Dutch and German areas of the United States used a wider sculpted board instead of the narrow post.

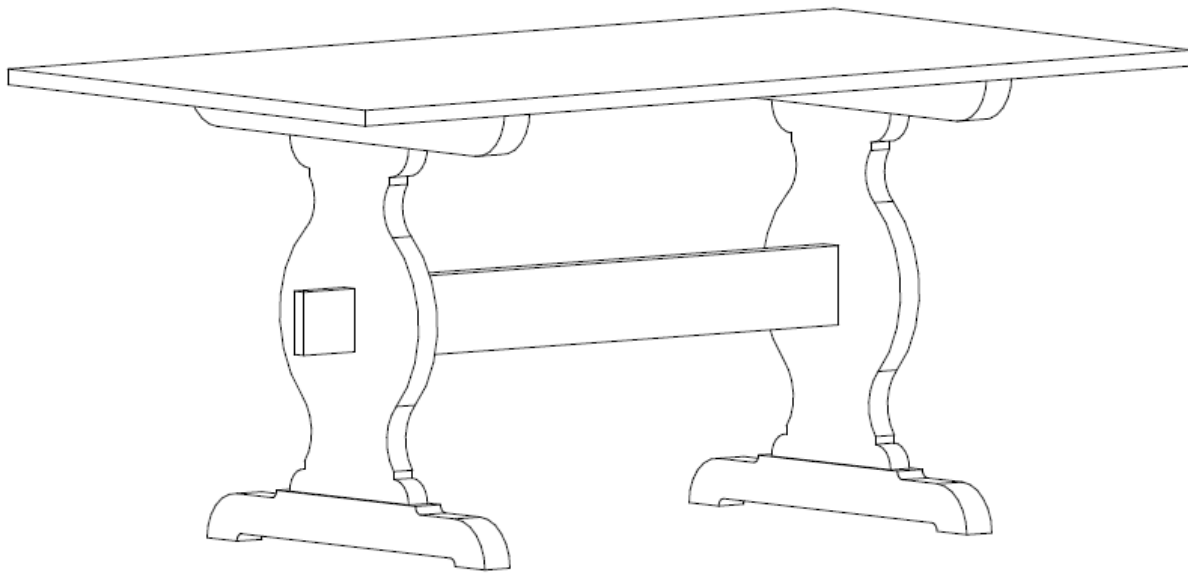

A variation adopted by the Shakers had an arch shaped foot. (The typical Shaker trestle table often elevated the stretcher to just below the tabletop, but this proved to have structural problems.)

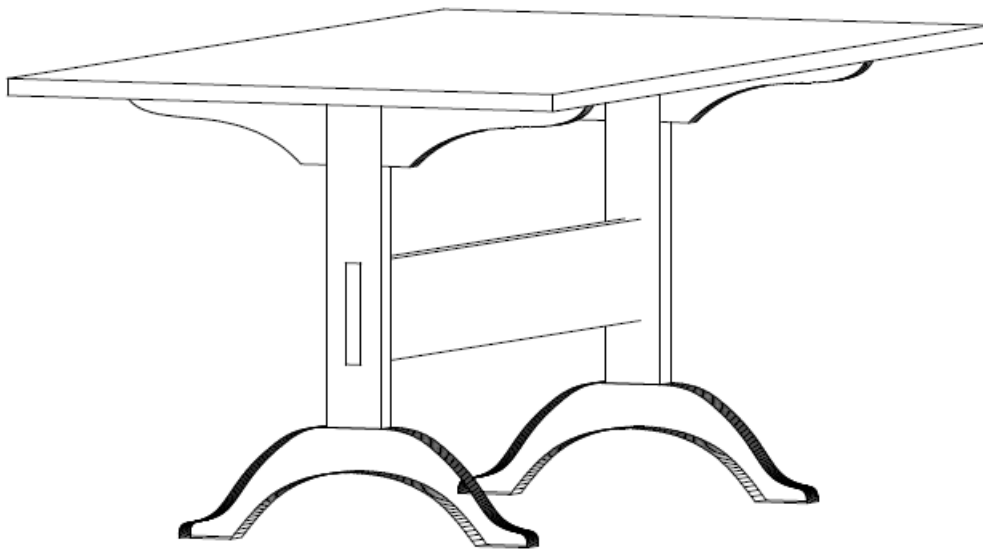

The single post at each end, including the sculpted board, have structural problems when the tabletop is wider than about 36". Then two posts and two stretchers are used.

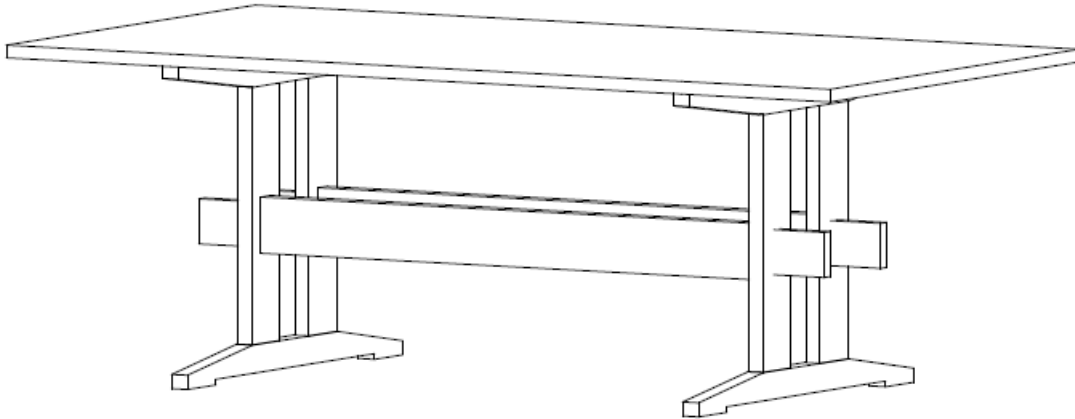

To accommodate diners at the ends of a trestle table, the overhang should be 16-18”.

### **Board Tabletops**

Traditionally the most common construction, solid wood runs the length of the top.

### **Breadboard End Tabletops**

This is a modification of board tabletops, where single 2-3” wide boards run across the ends of the top. The purpose is to avoid a wide expanse of end grain and to add a bit of detail to the appearance.

There is a cross-grain issue between the main body of the top and the breadboard ends. Therefore the ends are glued only in the middle, and held with wooden pins to allow the main body of the top to expand and contract as needed during the year.

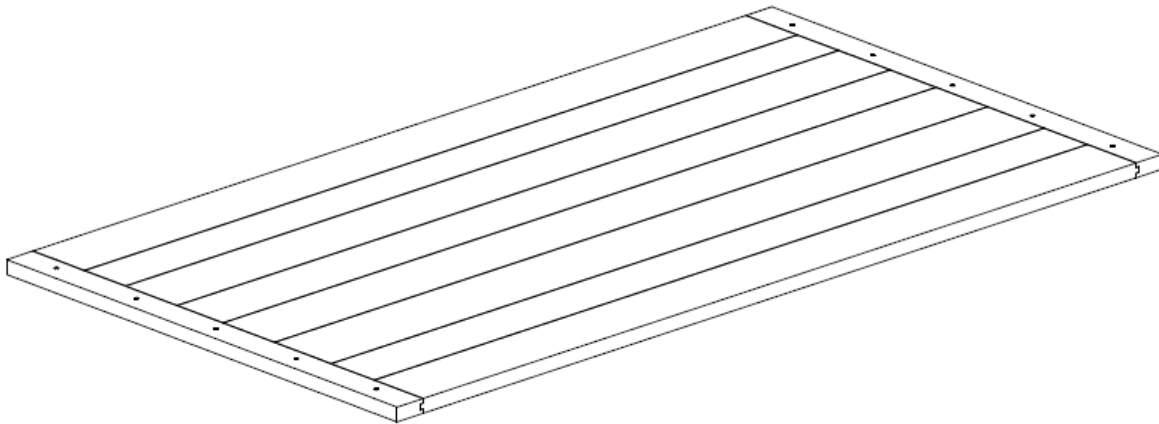

Following is a closer view of one of the corners.

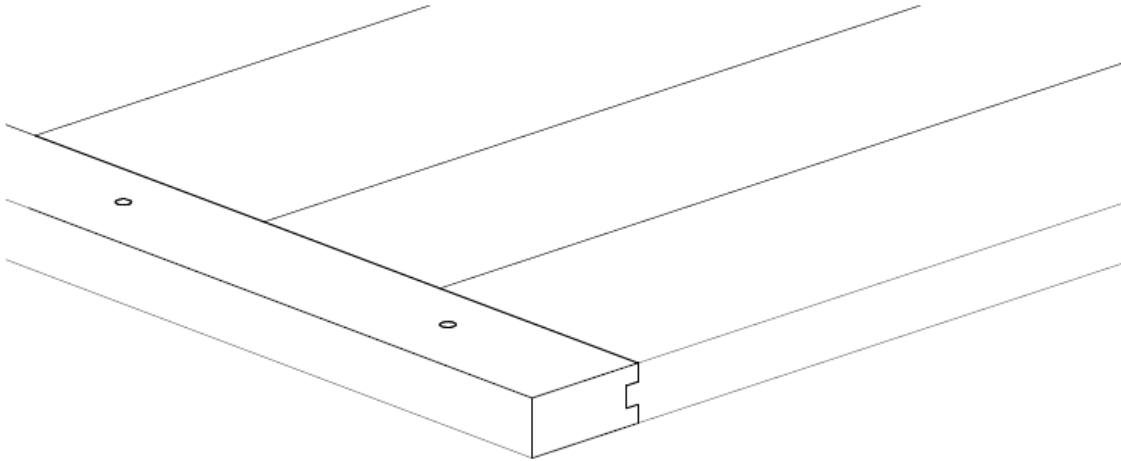

### **Veneered Tabletops**

Veneered tops are common on mass-produced dining tables to inexpensively simulate board tabletops and even breadboard end tabletops. However, veneer can be used quite effectively to create a number of very attractive looks.

On rectangular tabletops, very straightgrained veneer with perfect grain matching creates a more formal top than even carefully matched solid boards. Bookmatched mahogany swirl with satinwood crossbanding, or bookmatched walnut burl with quartersawn walnut crossbanding create a more elegant look.

Round tabletops can be given a subtle or spectacular 12, 16, or 24 piece starburst matching pattern.

Square tabletops can be treated to a bookmatched or double bookmatched burl or a diamond or reverse diamond pattern using very straight grained veneer.

### **Beginning to Design a Dining Table**

Some of the initial questions are how formal a look is desired, how many people should the table accommodate comfortably, how much floor space is available, and what type(s) of seating will be used (dining chairs, arm chairs, bench seats, wheelchairs, et cetera).

Pieces of newspaper cut into different sizes (24" x 16" and 30" x 18") can be very helpful in determining the desired place setting size.

Along with basic dimensions, newspaper and magazine advertisements, catalog pictures, and even camera photos are most helpful in beginning the actual design.

Common solid wood choices that tolerate use very well are cherry, maple, oak, and walnut. Mahogany always looks very elegant but is becoming harder to find. African mahogany (sapelle) looks very similar to genuine mahogany but is slightly hard to work with. Lyptus is a hybrid, sustainably harvested mahogany substitute but suffers from more color variation between boards and thus presents additional challenges during staining. Western alder when finished looks very much like cherry, but will have some knots because of its growth pattern. Thicker alder boards are not as widely available, meaning glueups will be needed for even 1 ½"

thick legs. Sugar pine is a classic look for informal tables, but because the wood is softer, hard built-up finishes are more likely to chip over time. Poplar is often recommended for painted finishes, but its softness can make paint chips likely over time.

Revised 16 January 2014 Page 16

6406 Madison Road Cincinnati OH 45227-2024 513-476-7929

[www.stephanwoodworking.com](http://www.stephanwoodworking.com)  
[www.stephanwoodworking.com/blog/wp/](http://www.stephanwoodworking.com/blog/wp/)

[don.stephan@stephanwoodworking.com](mailto:don.stephan@stephanwoodworking.com)  
[www.facebook.com/stephanwoodworking](http://www.facebook.com/stephanwoodworking)